

# RF MOSFET Power Transistor, 5W, 28V

## 100 - 500 MHz

UF2805B

V2.00

### Features

- N-Channel Enhancement Mode Device
- DMOS Structure
- Lower Capacitances for Broadband Operation
- Common Source Configuration
- Lower Noise Floor
- 100 MHz to 500 MHz Operation

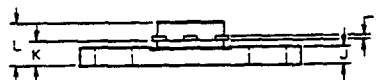
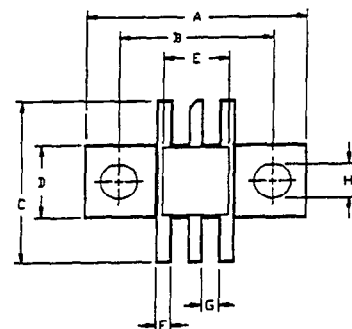

### Absolute Maximum Ratings at 25°C

Parameter	Symbol	Rating	Units
Drain-Source Voltage	$V_{DS}$	65	V
Gate-Source Voltage	$V_{GS}$	20	V
Drain-Source Current	$I_{DS}$	1.4	A
Power Dissipation	$P_D$	14.4	W
Junction Temperature	$T_J$	200	°C
Storage Temperature	$T_{STG}$	-55 to +150	°C
Thermal Resistance	$\theta_{JC}$	12.1	°C/W

LETTER DIM	MILLIMETERS		INCHES	
	MIN	MAX	MIN	MAX
A	20.70	20.96	.815	.825
B	14.35	14.61	.565	.575
C	14.73	15.24	.580	.600
D	6.27	6.53	.247	.257
E	6.22	6.48	.245	.255
F	1.14	1.40	.045	.055
G	1.52	1.78	.060	.070
H	2.92	3.17	.115	.125
J	1.40	1.65	.055	.065
K	2.03	2.39	.080	.094
L	3.66	4.32	.144	.170
M	.10	.15	.004	.006

### Electrical Characteristics at 25°C

Parameter	Symbol	Min	Max	Units	Test Conditions
Drain-Source Breakdown Voltage	$BV_{DSS}$	65	-	V	$V_{GS}=0.0\text{ V}, I_{DS}=2.0\text{ mA}$
Drain-Source Leakage Current	$I_{DSS}$	-	1.0	mA	$V_{DS}=28.0\text{ V}, V_{GS}=0.0\text{ V}$
Gate-Source Leakage Current	$I_{GSS}$	-	1.0	$\mu\text{A}$	$V_{GS}=20\text{ V}, V_{DS}=0.0\text{ V}$
Gate Threshold Voltage	$V_{GS(TH)}$	2.0	6.0	V	$V_{DS}=10.0\text{ V}, I_{DS}=10.0\text{ mA}$
Forward Transconductance	$G_M$	80	-	mS	$V_{DS}=10.0\text{ V}, I_{DS}=100.0\text{ mA}, \Delta V_{GS}=1.0\text{ V}, 80\text{ }\mu\text{s Pulse}$
Input Capacitance	$C_{ISS}$	-	7	pF	$V_{DS}=28.0\text{ V}, F=1.0\text{ MHz}$
Output Capacitance	$C_{OSS}$	-	5	pF	$V_{DS}=28.0\text{ V}, F=1.0\text{ MHz}$
Reverse Capacitance	$C_{RSS}$	-	2.4	pF	$V_{DS}=28.0\text{ V}, F=1.0\text{ MHz}$
Power Gain	$G_p$	10	-	dB	$V_{DS}=28.0\text{ V}, I_{DO}=50.0\text{ mA}, P_{OUT}=5.0\text{ W}, F=500\text{ MHz}$
Drain Efficiency	$\eta_D$	50	-	%	$V_{DS}=28.0\text{ V}, I_{DO}=50.0\text{ mA}, P_{OUT}=5.0\text{ W}, F=500\text{ MHz}$
Load Mismatch Tolerance	VSWR-T	-	20:1	-	$V_{DS}=28.0\text{ V}, I_{DO}=50.0\text{ mA}, P_{OUT}=5.0\text{ W}, F=500\text{ MHz}$

Typical Broadband Performance Curves

CAPACITANCES vs VOLTAGE

F=1.0 MHz

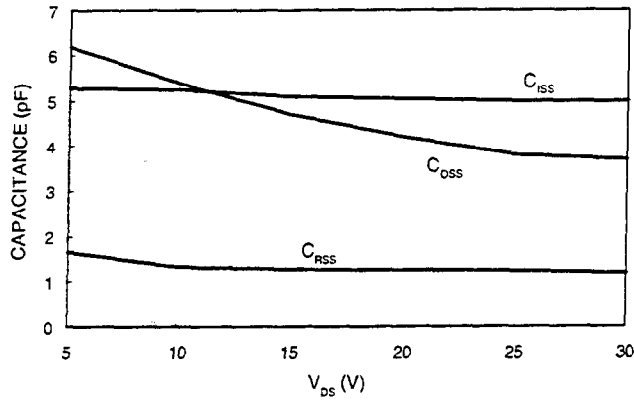

POWER OUTPUT vs VOLTAGE

$P_{IN}=0.3\text{ W}$   $I_{DO}=5.0\text{ mA}$   $F=500\text{ MHz}$

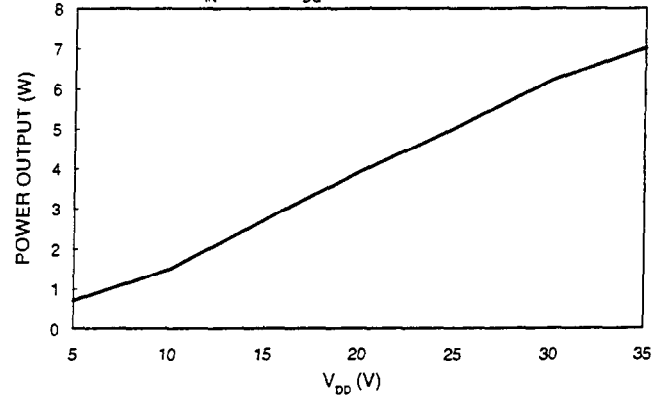

GAIN vs FREQUENCY

$V_{DD}=28\text{ V}$   $P_{OUT}=5.0\text{ W}$   $I_{DO}=50\text{ mA}$

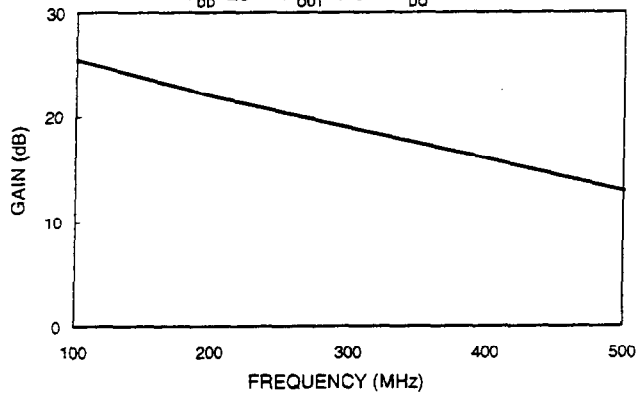

EFFICIENCY vs FREQUENCY

$V_{DD}=28\text{ V}$   $I_{DO}=50\text{ mA}$   $P_{OUT}=5.0\text{ W}$

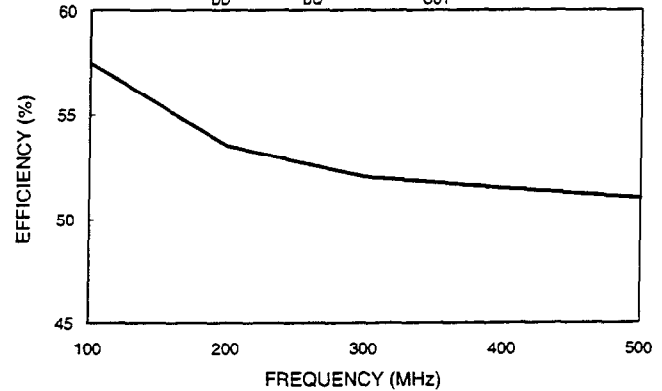

POWER OUTPUT vs POWER INPUT

$V_{DD}=28\text{ V}$   $I_{DO}=50\text{ mA}$

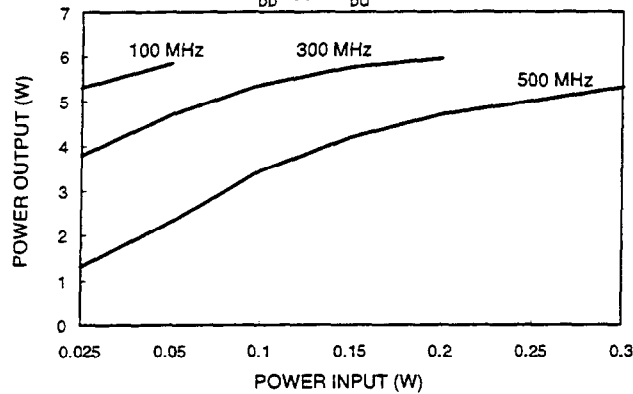

## Typical Device Impedance

Frequency (MHz)	$Z_{IN}$ (OHMS)	$Z_{LOAD}$ (OHMS)
100	15.0 - j 80.0	35.0 + j 55.0
300	8.0 - j 43.0	29.0 + j 40.0
500	4.0 - j 29.0	28.0 + j 29.0

$$V_{DD}=28 \text{ V}, I_{DO}=50 \text{ mA}, P_{OUT}=5.0 \text{ Watts}$$

$Z_{IN}$  is the series equivalent input impedance of the device from gate to source.

$Z_{LOAD}$  is the optimum series equivalent load impedance as measured from drain to drain.

## RF Test Fixture

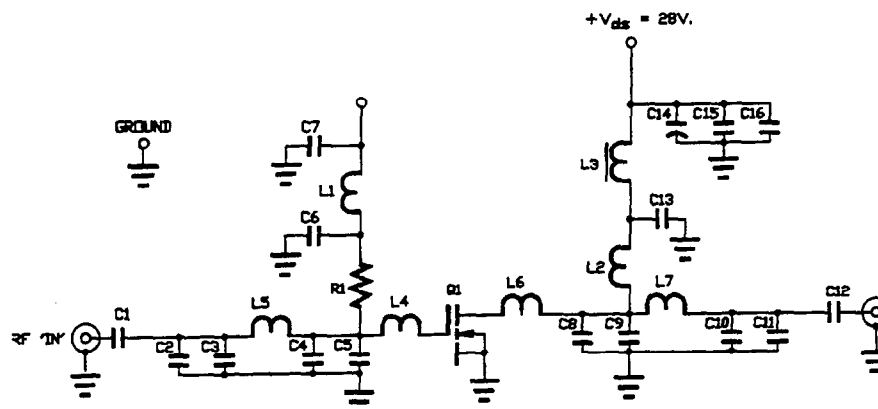

## PARTS LIST

C8	1.0pf
C9	3.9pf
C4, 10, 11	4.7pf
C2	5.6pf
C3	8.2pf
C5	15pf
C6, 7, 13, 16	680pf
C1, 12	820pf
C15	.01uf
C14	50uf 50V.
R1	10K OHM
Q1	UF2805B
L1	9 TURNS OF NO. 24 AWG
L2	7 TURNS OF NO. 22 AWG
L3	3 TURNS OF NO. 24 AWG ON FERRITE BEAD
L4	1.30' OF 50 OHM TRANSMISSION LINE
L5	.70' OF 50 OHM TRANSMISSION LINE
L6	.20' OF 50 OHM TRANSMISSION LINE
L7	1.85' OF 50 OHM TRANSMISSION LINE